

MONUMENT BUILDERS



OF NORTH AMERICA

CRATING INSTRUCTIONS

CRATING SPECIFICATIONS - All crates must be constructed in such a manner that they can be easily opened and kept intact for reshipment.

Show Management rules state that if any monument exhibitor does not follow the published crating procedure, said units will be re-crated and the exhibitor will be fined. **THIS WILL BE STRICTLY ENFORCED.**

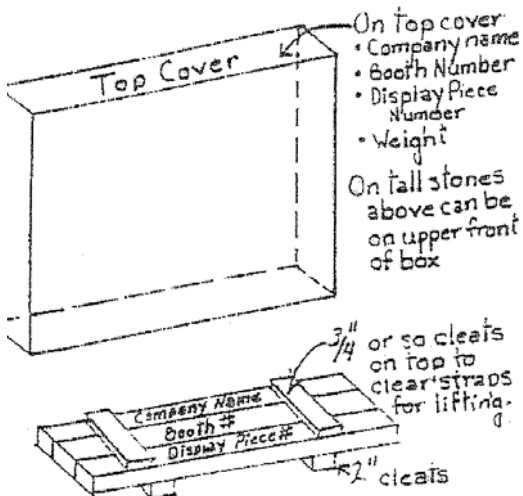

CRATING INSTRUCTIONS FOR DIES, MONOLITHS, WINGS, ETC.

- All dies are to be crated in a solid wood, Slip-Over Crate.
- The bottoms of crates are to be made of 2" boards.
- All crates are to have cleats on the bottom with a lull 2" high, for the forklift.
- All crates are to be bound with steel straps. No nails or screws are to be used to attach tops and bottoms of crates.
- Pressed board padding is suggested as a lining for all crates. Do not use excelsior or similar stuffing.
- Each piece of the crate is to be marked with a sturdy label (see enclosed template) as follows:

On Top Cover:

Company Name
Booth #
Display Piece #
"CRATE OF" _____ Weight in lbs.

On Bottom Piece:

Company Name
Booth #
Display Piece #
_____ Weight in lbs.

IDENTIFICATION OF DISPLAY PIECES

a. All pieces of display must be identified on the monument using ink or paint as follows:

Company Name

Booth #

Display Piece #

_____ Weight in lbs

b. Be sure display piece # corresponds to identification on booth layout sent to MBNA.

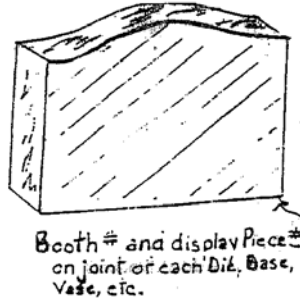

CRATING INSTRUCTIONS FOR BASES, PEDESTALS, VASES, ETC

a. All bases are to be crated in a solid wood, SLIP-OVER CRATE. The monument should be standing upright, not on its side, in the crate.

b. The bottoms of crates are to be made of 2" boards.

c. All crates are to have cleats on the bottom a full 2" high, for forklift straps. In addition, $\frac{3}{4}$ " cleats on top (as shown in the figure - crating dies) should be provided to clear forklift straps.

d. All crates are to be bound with steel straps. No nails or screws are to be used to attach tops and bottoms of crates.

e. Pressed board padding is suggested as a lining for all crates.

f. Each piece of the crate is to be marked with sturdy labels (see the enclosed template) as follows:

Company Name

Booth #

Display Piece #

_____ Weight in lbs.

g. Any dowel pins required for monuments must be securely attached to the proper crate, preferably attached to the base crate of the unit.

WHENEVER POSSIBLE, UNITS SHOULD BE GROUPED TOGETHER AND PLACED ON PALLETS WITH UP TO 4,000 POUNDS ON EACH PALLET.